

# Relcom

## Instructions for the use of Fieldbus Wiring Blocks in Hazardous Areas:

**FCS-TI Terminator**  
**FCS-S Spur**  
**FCS-E Expander**

Industrial areas, where Fieldbus network wiring, wiring terminal blocks and other devices are installed, may be **hazardous**. This has a specific meaning -- the atmosphere in these areas may contain gasses or dust that can ignite or explode. Various methods exist for dealing with these hazards. One of these methods is to use **intrinsically safe** equipment in the hazardous area. This requires that the electrical energy on the Fieldbus wiring and in the devices attached to the wiring to be very low so that the atmosphere in the hazardous area can not be ignited.

For the Fieldbus system (the combination of wiring and all connected devices) to be intrinsically safe, a number of requirements need to be met:

1. The electrical energy supplied to the devices over the wiring must be very low. These requirements are shown in Table 1 below. By passing the power and the signals from a safe area through an **intrinsic safety barrier**, the electrical energy to the hazardous area is kept within the required limits.
2. Each of the devices in the hazardous area must be intrinsically safe. This means that devices do not use the energy provided in a way that can cause ignition or store the supplied energy and release it in a way that can cause ignition.
3. The system as a whole must be certified to be intrinsically safe. This assures that any energy storage capabilities of the individual devices on the network do not combine to become a potential source of ignition.

Detailed requirements for intrinsic safety certification of a Fieldbus system are beyond the scope of this installation note. However, here are some requirements for a system when using Relcom's Fieldbus Wiring Terminal Blocks:

The Figure 1 below shows a representative Fieldbus system.

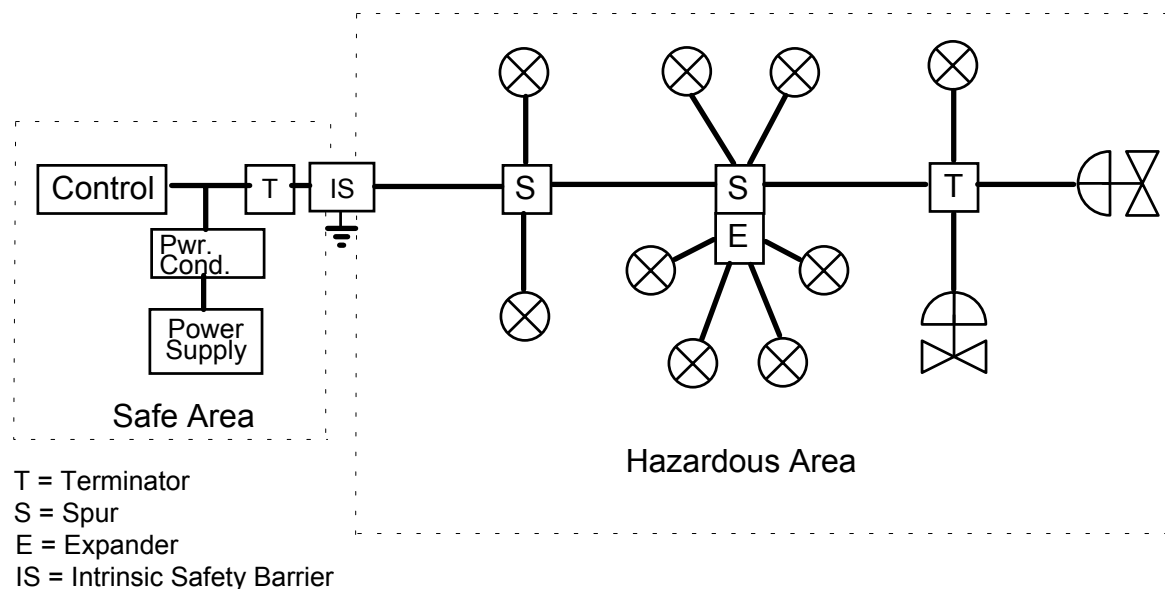

Figure 1

The safe area is usually the control room and the hazardous area is usually the field or a production area. The equipment in the safe area does not need to be intrinsically safe. The safe area contains, among other control equipment, the power supply and power conditioner that provide energy to the Fieldbus wiring. The Fieldbus wiring going from the safe area to the hazardous area must pass through an intrinsic safety barrier. Do not power the Fieldbus network from two or more intrinsic safety barriers.

**WARNING: ONLY ONE SOURCE OF SUPPLY SHALL BE CONNECTED TO A SINGLE TERMINAL BLOCK OR COMBINATION OF TERMINAL BLOCKS.**

The requirements for maximum electrical power that may be applied to Relcom’s Wiring Terminal Blocks in various types of hazardous areas are shown below:

GAS GROUPINGS			
North America	A, B	C	D
IEC	IIC	IIB	IIA
ENTITY PARAMETERS			
Vmax	22 V	22 V	22 V
Imax	224 mA	575 mA	781 mA
Ci	0 uF	0 uF	0 uF
Li	0 uH	0 uH	0 uH

Table 1

Note that the first two entity parameters in Table 1 show that all the hazardous areas limit the available voltage to 22 Volts, but the different hazardous areas have different maximum current allowances. These requirements are met by using a certified intrinsic safety barrier with the required specifications.

The last two entity parameters in Table 1 show that Relcom’s Wiring Terminal Blocks do not have any energy storage capability ( $C_i = 0$  and  $L_i = 0$ ). This means that any number of Relcom Wiring Terminal Blocks can be used in any combination with one another. Other devices attached to the wiring or to the Wiring Terminal Blocks may have energy storage characteristics and need to be certified individually and in a system to meet intrinsic safety requirements.

**WARNING: SUBSTITUTION OF COMPONENTS MAY IMPAIR INTRINSIC SAFETY.**

For answers to any questions about Fieldbus wiring or the use of the Wiring Terminal Blocks, please contact:

Relcom Inc. 2221 Yew Street Forest Grove, OR 97116 USA	Tel: 503-357-5607 Fax: 503-357-0491 fieldbus@relcominc.com
--	--